

4

3

2

1

NOTES, UNLESS OTHERWISE SPECIFIED

- 1. UNSPECIFIED FILLET RADII .005-.010.
- 2. MATERIAL: AL BAR 6061-T651
- 3. THREADS PER ANSI B1.1.

REV	ZONE	DESCRIPTION	APPROVED	DATE
-		INITIAL RELEASE		

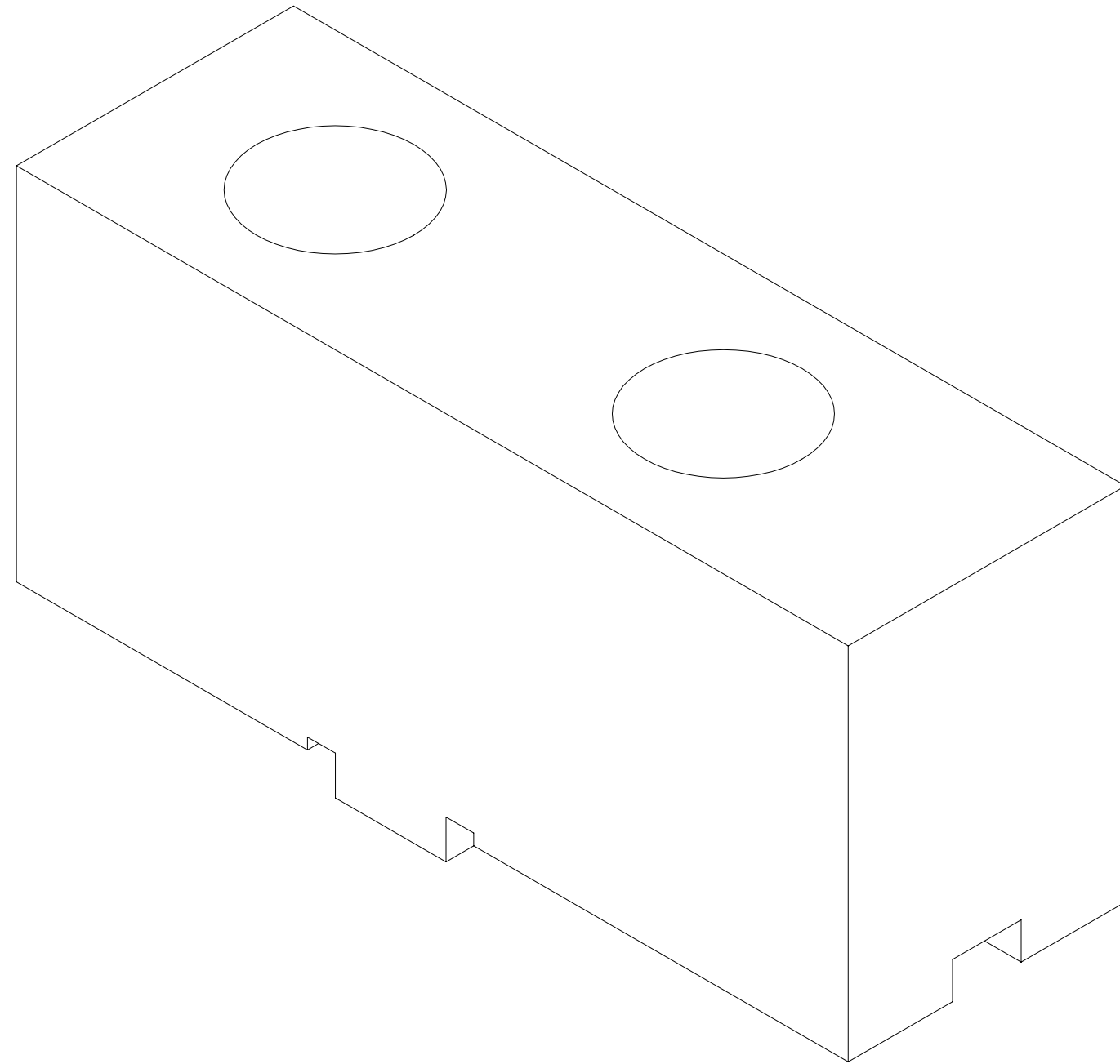

ALL DIMENSIONS ARE IN INCHES- INTERPRET DRAWING PER ASME Y14.5 -1994

TOLERANCES UNLESS OTHERWISE SPECIFIED:
 X.X ± .03 $\angle \pm .5^\circ$
 X.XX ± .01
 X.XX ± .005 125/

REMOVE ALL BURRS AND SHARP EDGES
 .005 R OR CHAMFER MAX

APPROVED	DATE
PREP BY	
CHECKED	
RESP ENG	
MFG ENG	
QUAL ENG	

Franklin W. Olin
 College of Engineering

PROJECT 3A
 MEASURE AND DRAW

SIZE C	FSCM NO.	PART NO. 1000-01	PART REV	DOC REV A
SCALE 2:1	WT 1.83	SHEET 1	OF 1	

4

3

2

1

↑

1

D

C

B

A

D

C

B

A