

4

3

2

1

NOTES, UNLESS OTHERWISE SPECIFIED

- 1. UNSPECIFIED FILLET RADII .005-.010.
- 2. MATERIAL: AL PLATE 6061-T651
- 3. THREADS PER ANSI B1.1.

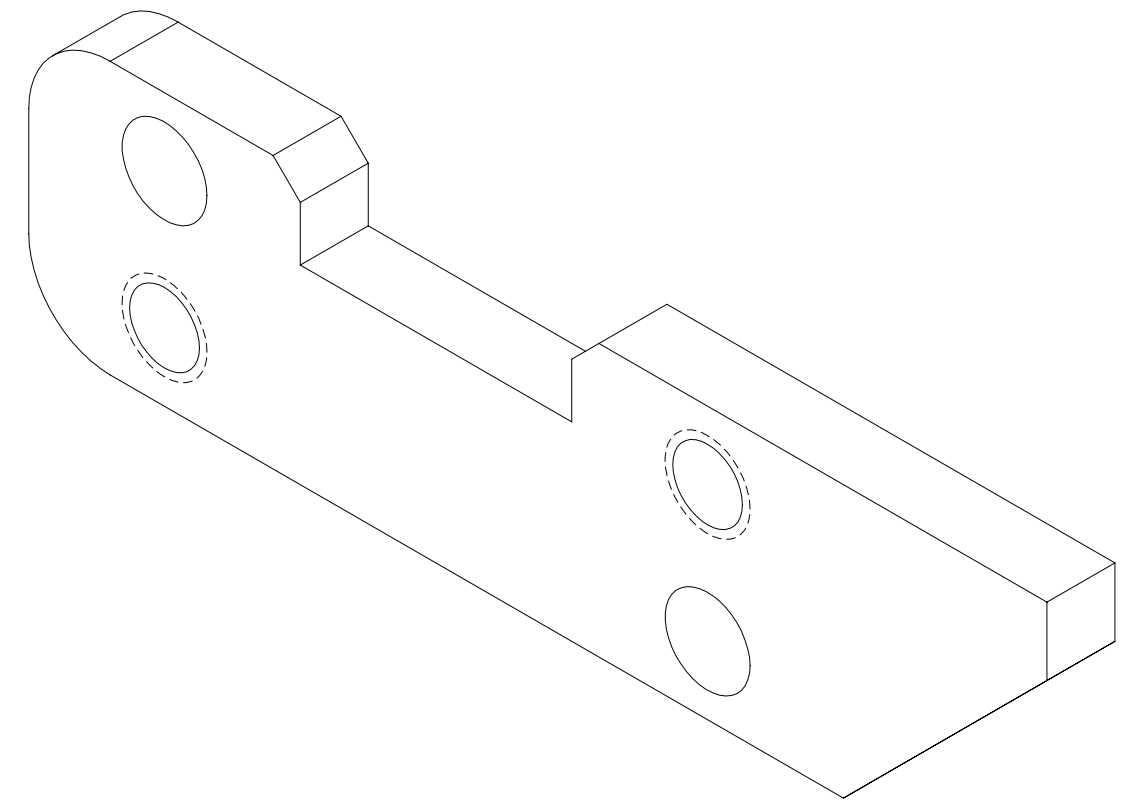
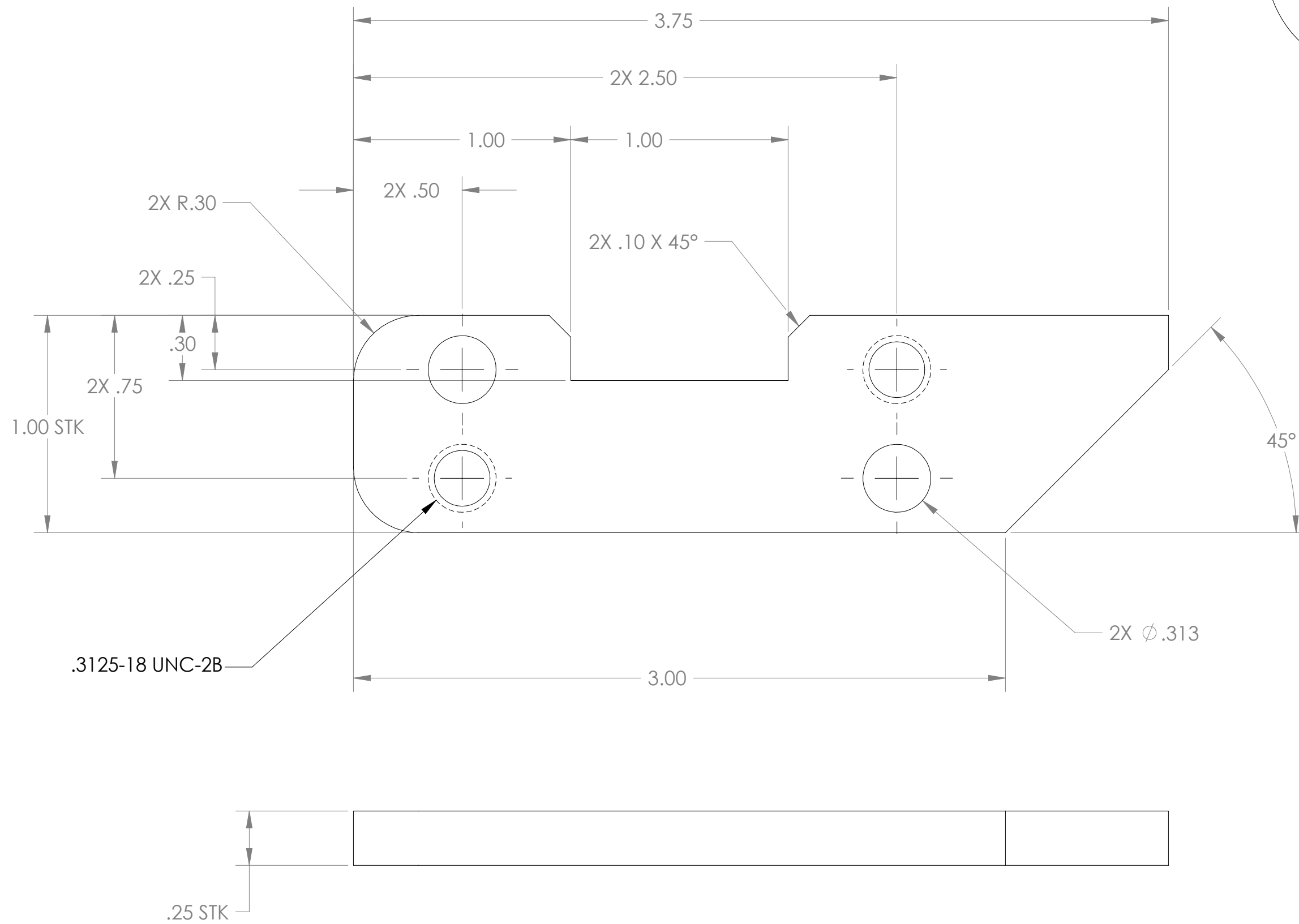

ALL DIMENSIONS ARE IN INCHES- INTERPRET DRAWING PER ASME Y14.5 -1994

TOLERANCES UNLESS OTHERWISE SPECIFIED:

X.X ± .03 \angle ± .5°

X.XX ± .01

X.XX ± .005 125

REMOVE ALL BURRS AND SHARP EDGES .005 R OR CHAMFER MAX

APPROVED	DATE
PREP BY D. ANDERSON	
CHECKED	
RESP ENG	
MFG ENG	
QUAL ENG	
◆ = (CRITICAL DIMENSION)	

Franklin W. Olin College of Engineering

PROJECT 5
SAWING, SANDING & THREADING

SIZE C	FSCM NO.	PART NO.	PART REV	DOC REV
SCALE 2:1	WT	SHEET 1	OF 1	

4

3

2

1

↑

1